



PROFIBUS DP/PA Coupler(Converter) User Manual(V10)



Introduction

DP/PA coupler BFP is conversion device between fieldbus PROFIBUS DP and PROFIBUS PA, which can convert and transfer data between this device.

The BFP module can be used independently, but also can be used with **our fieldbus distributor** with redundant structure of ring network on ROFIBUS PA segment.

Below is an integration of BFP application

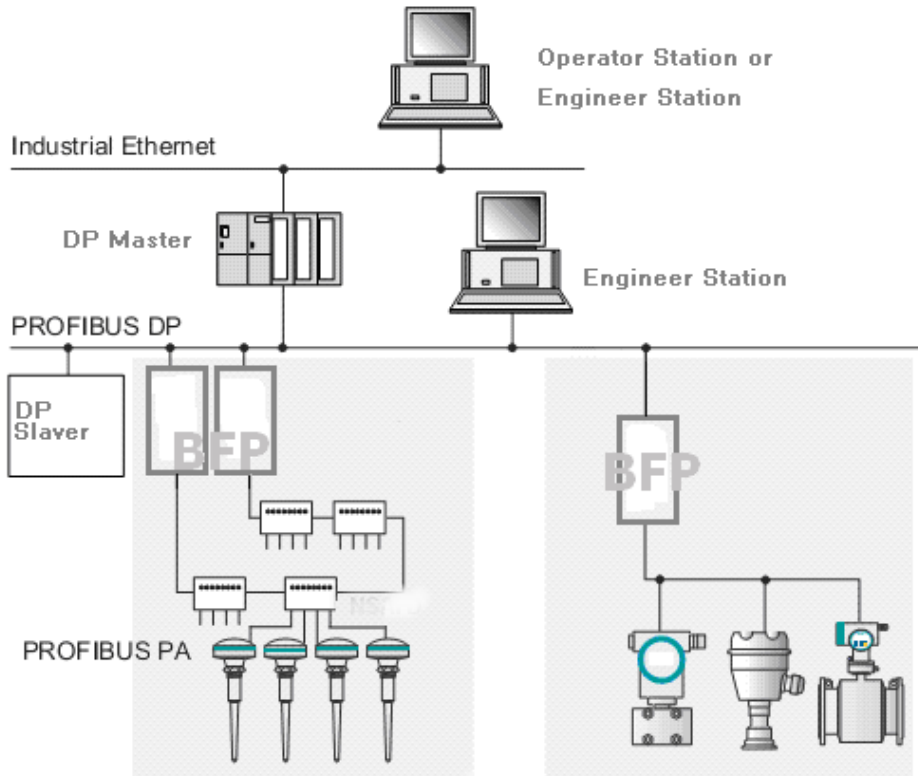

Functions and Characters

- Bidirectional conversion between Profibus DP and Profibus PA
- Each module include one or two Profibus DP electric interface,
- Each module include one or two PA segments
- Can achieve higher redundant network which include dual modular redundant
- Data coupling in Profibus DP and Profibus PA is c transparent
- It does not require a configuration, the application is simple and convenient
- Profibus DP interface
 - Support bus rates 45.45K, 93.75K, 187.5K, 500KBaud

- As a DP slaver station on DP segment
- Can realize FR redundant function on dual DP interface
- Support draping alarm function, when in redundant network, can timely find fault operation, convenient maintenance
- Interface is 9 holes Sub-D connector (female). You can access a conforms to the PROFIBUS standard twisted-pair cable
- Can achieve dual modular redundancy
- Profibus PA interface
 - Signal transmission rate is 31.25kbaud
 - Current drive capability up to 500mA
 - Support short circuit protection
 - Support draping alarm function when PA network redundancy
 - Can realize redundant function when used one BFP
 - support draping alarm function when in dual modular redundant network,
- Power is DC24V (20.4V-28.8V)
- With failure alarm relay output
- 6 double color LED indication module current states
- Metal casing, rail type installation

Model and naming rules

BFP series products with high performance and powerful functions, there are many types of products, the following is the naming rules of product type.

This series product models consists of three parts:

The first part is the series' BFP '

The second part is PA port driver capability , is a digital, values of 1-4, its meaning is as follows:

- 1 - One PA port current drive capability is 500mA
- 2 - One PA port current drive capability is 360mA
- 3 - One PA port current drive capability is 240mA
- 4 - One PA port current drive capability is 110mA

The third part is the function code product,, they are in any combination, no function in the model does not exist, as follows:

- A - Variable rate function, when no this function, DP only supports 45.45K rate
- B - Double PA port function, this feature is not only the products available PA1 port
- C - Modular redundancy function, not include this function products can only be run independently, can not realize the modular redundancy
- D -- Double DP interface function, not include this function the product is only available DP1 port, can not achieve redundancy DP network
- E - Test mode enable, when having the function, each powerup, running about 16 hours
- F - Coating protection function, has this function product is coated with protection, suitable for the specific application environment

Common product models of BFP

Model	Description
BFP001	DP/PA bidirectional coupling, single DP port, support rates: 45.45Kbps, single PA port, 31.25Kbps, current drive capability is 360mA, DC24V power supply. Relay alarm output, D35 rail mounted, metal die-casting machine
BFP002	DP/PA bidirectional coupling, single DP port, support rates: 45.45Kbps, single PA port, 31.25Kbps, current drive capability is 500mA, DC24V power supply. Relay alarm output, D35 rail mounted, metal die-casting machine
BFP003	DP/PA bidirectional coupling, single DP port, support rates: 45.45Kbps, double PA port, 31.25Kbps, current drive capability is 500mA pre PA port, DC24V power supply. Relay alarm output, D35 rail mounted, metal die-casting machine
BFP004	DP/PA bidirectional coupling, double DP port, support master redundancy at DP port, at the same time support dual-module BFP redundancy function, support rates: 45.45Kbps, double PA port, rate of 31.25Kbps, current drive capability is 500mA for each PA interface, supports PA port redundancy, DC24V power supply. Relay alarm output, D35 rail mounted, metal die-casting machine
BFP005	DP/PA bidirectional coupling, single DP port, support rates: 500Kbps, 187.5Kbps, 93.75Kbps, 45.45Kbps, single PA port, rate of 31.25Kbps, current drive capability is 500mA for each PA interface, DC24V power supply. Relay alarm output, D35 rail mounted, metal die-casting machine
BFP006	DP/PA bidirectional coupling, single DP port, support rates: 500Kbps, 187.5Kbps, 93.75Kbps, 45.45Kbps, double PA port, rate of 31.25Kbps, current drive capability is 500mA for each PA interface, supports PA port redundancy, DC24V power supply. Relay alarm output, D35 rail mounted, metal die-casting machine
BFP007	DP/PA bidirectional coupling, double DP port, support master redundancy at DP port, support rates: 500Kbps, 187.5Kbps, 93.75Kbps, 45.45Kbps, double PA port, rate of 31.25Kbps, current drive capability is 500mA for each PA interface, supports PA port redundancy, DC24V power supply. Relay alarm output, D35 rail mounted, metal die-casting machine
BFP008	DP/PA bidirectional coupling, double DP port, support master redundancy at DP port, support dual-module BFP redundancy function, support rates: 500K, 187.5K, 93.75K, 45.45K, double PA port, 31.25Kbps, current drive capability is 500mA pre PA port, supports PA port redundancy, DC24V power in. Relay alarm output, D35 rail mounted, metal die-casting machine
BFPC	Redundancy cable ,0.3 or 1.5 meter, Link Cable
-F	Coating protection function

Typical applications

There are many kinds of application of BFP, it has a variety of working mode. This module can be used alone, can also be used in combination with two modules. When used alone, two PA ports can be treated as two independent ports are respectively connected with the two PA segment, can also be used as a redundant port of one segment. The following is a typical application.

Non redundant network structure application

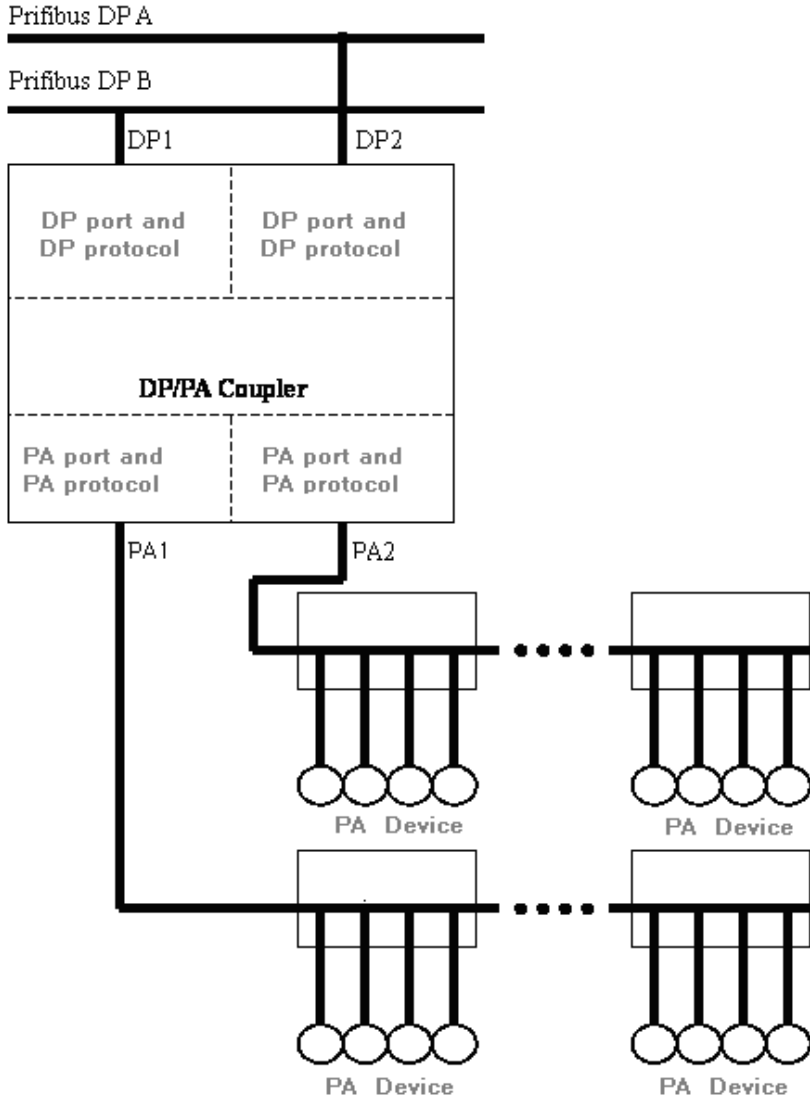

Note: In non redundant network structure application, the PA side fieldbus segment can be linear structure, and also can be single or dual fieldbus segment,,The distributor on Profibus PA segment can be used with **our PA distributor**.,When the distributor using the coupler, users need to manually through the switch to manager the bus terminal resistance.

Redundancy network structure application mode when BFP used alone

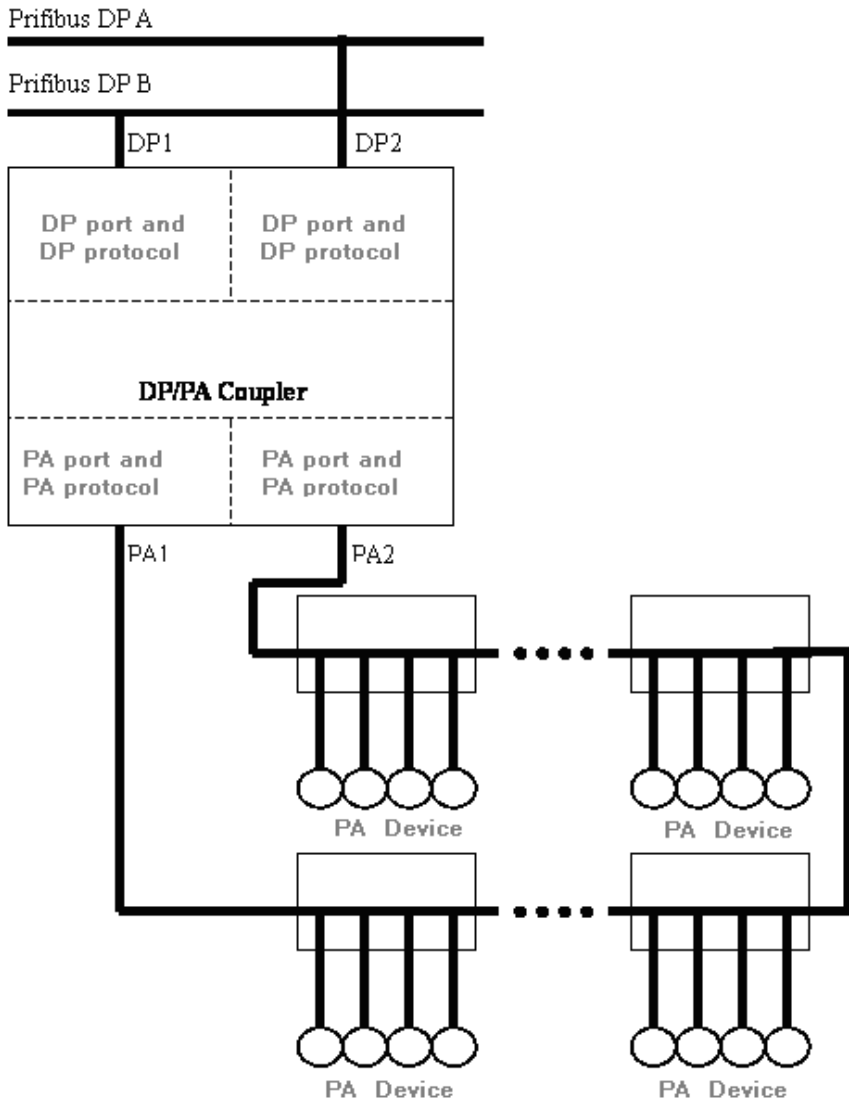

Note: In redundant network structure application mode when BFP used alone, the PA side fieldbus segment will be in ring structure, and only one fieldbus segment, The distributor on Profibus PA segment can only be used with our distributor, Setting the bus terminal resistance is automatically.

Redundancy network structure application mode when used dual module BFP

When BFP used in dual modular redundancy mode, the system can be composed of redundancy degree high, can solve two failures in 11 type failures as show fig. At the same time can achieve module redundancy protection.

In this applications, the two BFP module must be the same type, different types of products can not provide module redundancy

The redundant system power-up sequence requirements: before system power up, should be ensure that the Link Cable connection is good, if not ,the whole network communication may be interrupt. If the PA side without any device connection, so no effect on the DP side communication. In order to better prevent the effect of communication when power up, first determine the Link Cable connected correctly before power up (best is: not connected to the PA port before power up. After power on, then connect the PA cable, so , even the redundant cable is not plugged in, but because there is no PA side device can guarantee security). It is important for maintenance operation, because system is running in the operation of maintenance system. During the system running , breaking cable is fault, need treatment.

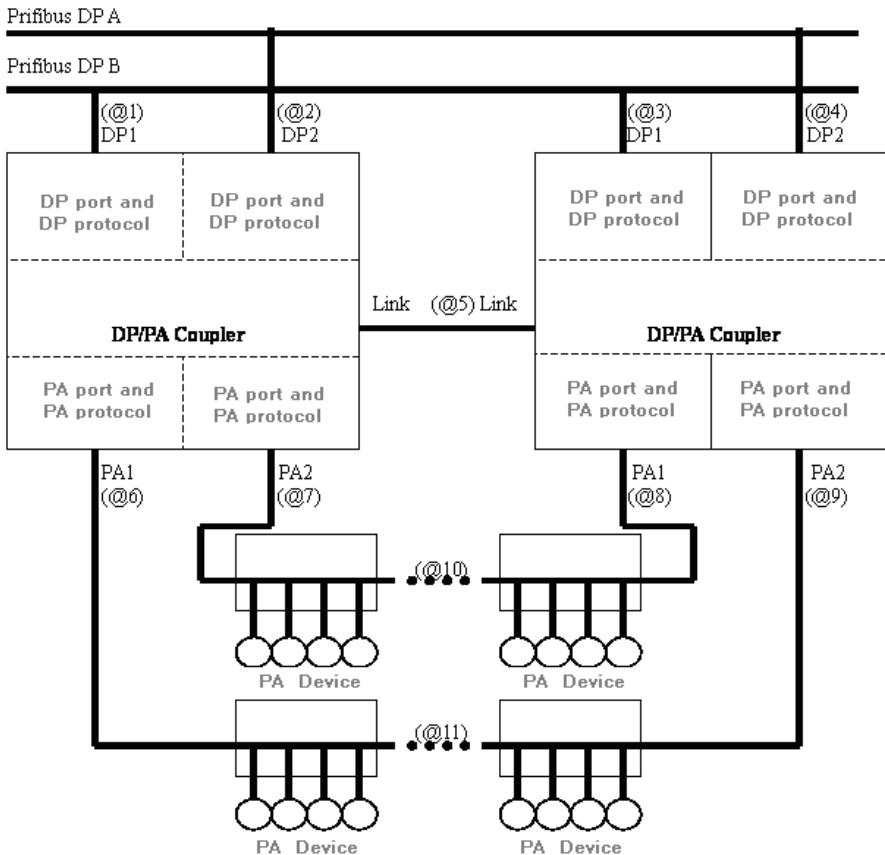

Note: In redundant network structure application when used dual module BFP, the PA side fieldbus segment will be in ring structure, and only one fieldbus segment, The distributor on Profibus PA segment can only be used with our distributor, Setting the bus terminal resistance is automatically.

Principle and Function Description

Function Block Diagram

As shown in figure, the module include following parts: two DP port; two PA port; Link port, Control center, Power part, Alarm and LED indicator.

The DP1 and DP2 port are independent transmission of redundant DP bus respectively and receives corresponding data, also can use only one DP port for receiving and sending data with non redundant DP bus. PA1 and PA2 port which separate transmit and receive PA bus data corresponding, at the same time, supply power to PA bus segment, Each PA port can be used independently, but also can binding the two PA bus port to realize the PA bus redundant features. Another important function of the module's interface is a Link port, through this port, control data and information of two modules can be shared, dual modular redundancy working mode can simultaneously achieve DP bus segmen and PA bussegment, when using the type network, fault of any module will not affect the PA the segment even if the module power down, the system possibility and reliability to achieve the most effective.

The most important part of this module is the Center of CPU module, completed the redundant transmission of double DP interface data and receiving control, data transmission and receiving transform PA interface conversion, while achieving the dual modular redundant state detection and important functions of switch control, and also has the auxiliary function of fault state of the output and the display of LED

The function module and the additional power supply, power function module for all circuit and PA port, Alarm module can create fault alarm signal, LED module is the display state.

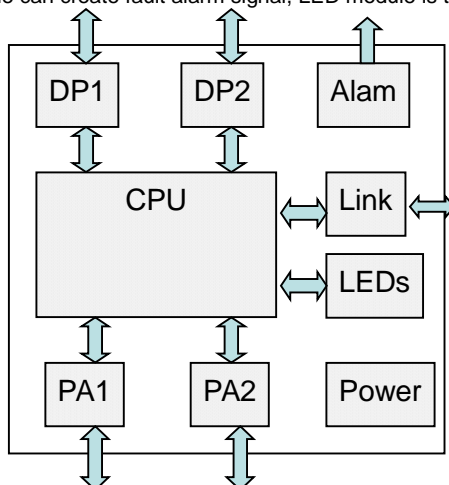

Important note: Data coupling between Profibus DP port and Profibus PA port is completely

transparent, that is to say, all Profibus slaver station on the PA bus completely display on the DP bus master, and the master station direct access to the Profibus PA slaver station on Profibus PA bus like access to Profibus DP slaver station. And so, Profibus Slaver station on PA bus will use Profibus slaver address on the DP bus.

Profibus DP Port

Bus rate on DP bus

On the DP side, support variable rates is one of the important features of this product, when the product support variable rate, at the DP bus can use 45.45K ~ 500K rate. This feature enable the system becomes simple.

Dual DP redundant

The BFP module with dual DP port, the DP1 port and the DP2 port support bus redundancy based on the Profibus FR redundancy ("Flying Redundancy", same below) function. On the DP side can be connected to a dual bus redundancy in the system with FR.

Bus signal regeneration

The modules regenerate the signal form and amplitude of the data received. This feature can improve the anti-interference performance, improve the operation reliability.

Monitoring of RS485 bus port state

Each receiver monitors the RS 485 bus segment connected to it for faulty frames or continuously busy networks. If faulty frames are received by the receiver, or if the network is busy for longer than the maximum permitted send time, forwarding of the received signals is blocked until frames can be received again correctly.

Dropping alarm DP port

In a redundant system with dual DP bus segment, when one segment of the connection failure, due to redundancy network, No effect occurs, but the bus segment or port is a failure, the system should provide the fault indicator. The DP dropping alarm function is to solve this problem. When the dual redundant DP system is running, if bus segment or port connection is a failure, the DP port detected fault, displayed on LED, output alarm through the relay.

Profibus PA Port

Power supply output to PA Segment

The PA port on BFP is power supply output interface ,and power supply for PA segment, The current output capacity of the port is divided into four types, corresponding to the 4 kinds of models, max driving ability can be drive 500mA.

Bus data transmission

PA port is power supply port , at the same time ,it is data communication port, can complete the bidirectional data communication between Profibus master station data and PA bus equipment in accordance with Profibus PA standard.

Double PA port can realize PA network redundancy

With dual PA port on BFP , BFP can support ring network redundancy on PA bus segment, when used BFP module and our bus distributor, two ends of PA bus segment can be connector to difference BFP, so, the two BFP can supply power or transmission data to same

PA bus at the same time. When the PA bus line broken, two sections of PA bus segment will be respectively connected with the equipment each by the original bus at both ends, power supply and communication and normal.

The PA port state

The modules regenerate the signal form and amplitude of the data received .Each receiver monitors the PROFIBUS PA bus segment connected to it for faulty frames or continuously busy networks. If faulty frames are received by the receiver, or if the network is busy for longer than the maximum permitted send time, forwarding of the received signals is blocked until frames can be received again correctly.bus will report this error and indicating by LED.

In a redundant PA segment system, when the PA network connection failure, due to redundancy network, No effect on running system, but the line is a fault, the system should provide the fault indicator, the module of the PA port can be faulty communication in PA network segment, this fault is detected, displayed by the LED, Output alarm by relay .

The Link interface

Implementation of dual redundant Module system

By connected redundant cable thorough link port, two BFP module can achieve dual modular redundancy network structure, as show above, using this model, the redundant DP network not only can be connected to the DP side, but also can be a ring network to protect the PA side of the segment, while the fault on one of this two module ,other module can also be normal operation to protect communication OK.

Dropping alarm of Link port

When connecting two BFP module through link port, module automatically enters the redundant working mode. In this working mode, if the redundant cable broken, short circuit faults, the Link interface can real-time detection of port status, once a fault is detected, will be dealt with immediately, and the indicating lamp and a relay alarm.

Setting Up

DANGER: Never connect the Module to the main power supply.

Select the network topology which is most suitable for your requirements

When select network topology, will be consider the redundancy network, and pay attention the driving ability of PA port and PA bus segment terminal resistance etc.. Especially the quantitative relationship between the number of PA device nodes and the driving ability of PA port, to ensure that in all conditions, the load current for PA bus should not be larger than BFP

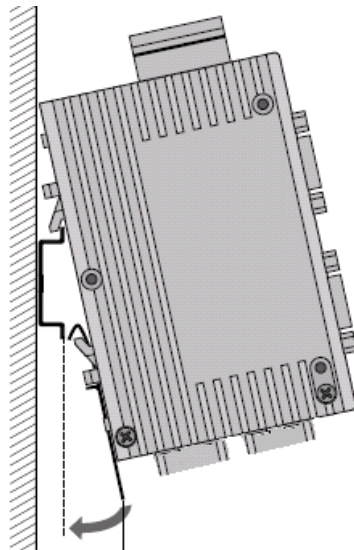

module driving ability; in order to have a certain margin, it is best to load current is not more than 85% of PA port driving ability.

Mount the modules

The modules can either be mounted on a 35 mm hat rail in accordance with DIN EN 50022 or directly on to a flat surface.

Only mount the module on a low-impedance and low-induction grounded hat rail or base plate. No other grounding measures are required.

Mounting on a hat rail

Hang the top snap-in hooks of the module into the hat rail and press the underside onto the rail (as show) until it audibly clicks in.

To remove the module, pull down on the locking slide.

Mounting on a mounting plate

The modules have three through-holes.

This allow it to be mounted on any flat surface, e.g. on the mounting plate of a switch cabinet.

Drill three holes in the mounting plate corresponding to the drilling template as show.

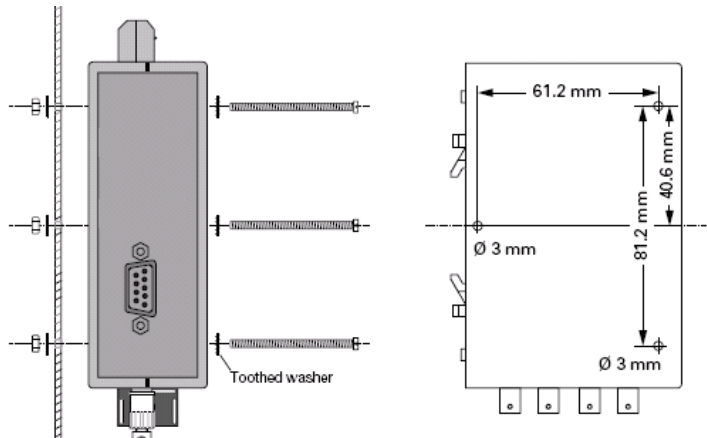

Secure the modules with machine bolts (e.g. M 3 x 40).

Ensure that there is a reliable electrical connection between the module housing and the mounting plate.

Place toothed washers under the bolt heads to pierce the varnish.

Connect the power supply and the signaling contacts

The terminal block can be removed from the device to connect the lines. It can be fed in using the 5-pin terminal block on the top of the module.

This module power supplied via the terminals L+ and M.

A relay with unconnected contacts as signaling contacts is fitted

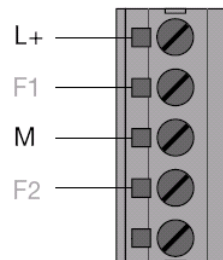

to the 5-pin terminal block on the top of the module. This signals faults and interference the ports and modules. The contact is open if a fault occurs. This also signals a total loss of power at the module.

The signaling contact can signal the failure of a single 24 V infeed. Both of the infeeds and the signaling contact must be connected to an input module for monitoring to take place. Clips on the terminal block ensure that it is securely attached to the device, and simultaneously provide polarity reversal protection.

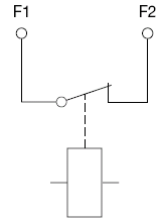

Connect the electric RS 485 bus line with bus connector

The modules are fitted with one or two RS 485 electrical port. Switch of this is 9-pin Sub-D socket with a screw lock. The pin assignment complies with the PROFIBUS standard. At Pin 6 there is a 5V output for supplying external resistors.

Only use shielded and twisted-pair wiring as a RS 485 bus line. Do not exceed the segment max lengths.

Use a PROFIBUS bus connector plug to connect the bus segment. If the module is at the beginning or end of a bus segment, this connector must have an activated bus terminal resistor combination.

Attach or remove the RS 485 bus connector plug quickly and without twisting them.

Remove the RS 485 bus line from the modules if a device is not connected to the other end, or which has been disconnected from the power supply. The open line otherwise acts as an antenna and can cause

interference. When connecting a RS 485 bus line to the BFP in an active network, keep to the following sequence in order to avoid interference:

1. Place the bus connector plug onto the device which is to be connected and screw it on tightly.
2. Attach the bus connector plug to the BFP quickly and without twisting the connector, and screw it on tightly.

Proceed in the reverse order when removing a device from the network

Ensure that the bus segment connected to the RS 485 interface is terminated at both ends. Only use a connecting cable which is terminated at both ends to connect a single device.

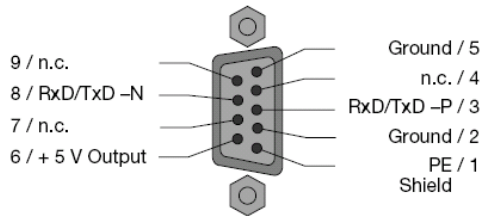

Connect the PA bus cable

The BFP module with one or two PA port, two interface connection mode is the same, each interface is a three line terminal: data line (+, red); data line (-, green), shield; As following diagram. Terminal of PA port is pluggable, wiring terminal, can be taken down, after connection, can be up to the terminal is inserted, it can be convenient for wiring operation.

The wiring is completed, the fixed screw fastening terminals on both sides, to ensure the safety and reliability of connection.



Redundant cable (Link Cable—BFPL)

When the network used dual modular redundancy working mode, need to connect the redundant cable – BFPL.

For redundant cable, usually the standard selection of redundant cable accessories BFPL, standard redundant cable length is 1.5 meters, so in redundancy mode, the installation distance of two modules have certain requirements, do not exceed the redundant cable length.

The parameter of DP segment settings

When using the BFP module, data exchange between master station and slaver station on Profibus PA is carried out through the BFP module. In the Profibus system, the data exchange is realized by the master polling, either the master station and the data exchange from the station, by the master to the slave station first sent a request to the data frame and waits for a response, if within the time stipulated in the bus parameters (Tslot, or Tsl to set this time) does not receive the corresponding data response, master that the communication failure, and asked again or other polling. When using the BFP module, the BFP exchange data need time, to the reliability of the communication, should adjust the waiting time to master communication time delay compensation communication process.

When the system using the BFP, the DP parameter should use the user-defined parameter setting, and sets the corresponding Tslot (Tsl):

DP segment bus rate	Tslot(Tsl) :tBits
45.45Kbps	748
93.75Kbps	1435
187.5Kbps	2760
500Kbps	7200

When the system using the BFP, while integrates 212 X optical module,as 212x module have delay characteristics, so the parameter Profibus is need change. In this application, the DP parameter should be the use of user-defined parameter setting, and sets the corresponding Tslot (Tsl):

DP segment bus rate	Tslot(Tsl): tBits
45.45Kbps	856
93.75Kbps	1550
187.5Kbps	2880
500Kbps	7360

Switch Settings

The switch S7..S0 is used to setting the functional of bus data rate and alam config.

S1	■ =1 (default) ■ =0	-Setting PA2 segment terminal resistor to 'ON' - Setting PA2 segment terminal resistor to 'OFF'
(S5..S2)	■ ="1111"(default) ■ ="0101" ■ ="0110" ■ ="0111" ■ ="1000" ■ =others	- Setting transmission rate in Automatic - Setting transmission rate at 500Kbps - Setting transmission rate at 187.5Kbps - Setting transmission rate at 93.75Kbps - Setting transmission rate at 45.45Kbps - Reserved
S6	■ =1 (default) ■ =0	-Setting PA1 segment terminal resistor to 'ON' -Setting PA1 segment terminal resistor to 'OFF'
S7	■ =1 (default) ■ =0	-Non redundancy or Not ABB system redundancy -System is ABB redundancy system
Others	■ =1	-Reserved

LED Indicators and Signaling contact

LED	Indicator	Status	Signaling contact
MS	■ not lit	-No power or device error	no signal
	■ lights red/red	-System error; clock error ;hardware error	signal
	■ flashes green(0.5s)	-Rate has not yet been recognized	no signal
	■ green	-Rate has been recognized and All OK	no signal
Link	■ not lit	-No used link port or no power	no signal
	■ red	-Link cable loose error	signal
	■ flashes red(0.5s)	-PA1 cable loose error in redundancy mode	signal
	■ flashes red(4s)	- PA2 cable loose error in redundancy mode	signal
	■ green	-In redundancy mode,link cable OK	no signal
DP1,DP2	■ lights/flash green	-In non-redundancy mode,data on optical port	no signal
	■ not lit	-No Data or no power	no signal
	■ red	-DP cable loose error	signal
	■ flashes red	-DP port error	signal
-Data error,bus rate not OK		nosignal	
PA1,PA2	■ lights/flash green	-Data OK,this module received	no signal
	■ not lit	-No Data or no power	No
	■ red	-PA port fault	signal
		-PA port short	signal
		-PA port current to large	signal
	■ flashes red(0.5s)	-PA port power error	signal
	■ flashes red(2s)	-PA port terminal resistor error	signal
■ flashes red/green	-Data error	nosignal	
■ flashes green/green	- Data OK,this module received	nosignal	

Technical Data

Voltage/power supply

Operating voltage

DC24V(20.4V....28.8V)

Reverse wiring ,Over voltage protection	Yes
Signaling contact	0.1A @ 250V AC (350V DC),MOS

Power supply on PA Segment

Output voltage	DC 31V(DC30V....32V)
Voltage monitoring	12V
Power failure bypass	min. 5ms
Input current	< 3A
Output current	
Up to 50° ambient temperature	< 500mA
Up to 60° ambient temperature	< 360mA

Isolation

Profibus DPx/Profibus PA	Yes
Profibus DPx/ Power supply	Yes
Profibus PAx/Power supply	Yes
Profibus DP1/Profibus DP2	Yes
All electric circuits/FE	Yes
Isolation test voltage	500V DC

DP electrical port

Transmission rate	45.45; 93.75; 187.5; 500 k Baud rate
Setting transmission rate	Automatic or Switch setting
Bus protocol	PROFIBUS DP
Input/output signal	RS 485 level
PIN assignment	EN 50170 Part 1

PA electrical port

Transmission rate	31.25k Baud rate
Bus protocol	PROFIBUS PA

Electromagnetic compatibility (EMC)

Limit class B (EN 55022)	
EN 61000-4-2	
EN 61000-4-3)	
Burst:On power supply lines and shielded RS 485 bus lines: ± 2 kV (EN 61000-4-4)	
Surge:– Power lines: ± 1 kV symmetrical,Shielded RS 485 lines: ± 2 kV asymmetrical (EN 61000-4-5)	

Others

Storage temperature	–40 °C to +85 °C
Relative humidity	<95 %, non-condensing
Protection class	IP 20
Dimensions (W x H x D)	40 x 110 x 74 mm
Housing material	Die-cast zinc
Weight	approx. 500 g