

# CANET-I/II Isolated CAN to Ethernet Converter

V1.0

## Contents

<b>Chapter 1 Product Overview.....</b>	<b>3</b>
<i>1.1 Product Overview.....</i>	3
<i>1.2 Parameters.....</i>	3
<i>1.3 Typical applications.....</i>	3
<i>1.4 Ordering Information.....</i>	3
<i>1.5 Product Sales list.....</i>	4
<i>1.6 PC-CAN Interface Card List.....</i>	4
<b>Chapter 2 Product Installation.....</b>	<b>5</b>
<i>2.2 Connector.....</i>	5
<i>2.2 CAN bus connections.....</i>	6
<i>2.3 Configing and Using the CANET-I/II.....</i>	7
2.3.1 Introduction for the Config software and parameters.....	7
2.3.2 Using the CANET-I/II.....	8
<b>Chapter 3 Application Software development.....</b>	<b>9</b>
<i>3.1 Communication Protocol.....</i>	9
<i>3.2 Examples.....</i>	10
<b>Appendix A: SJA1000 standard Baud rate.....</b>	<b>11</b>
<b>(Oscillator Frequency=16MHz).....</b>	<b>11</b>

## Chapter 1 Product Overview

### 1.1 Product Overview

CANET-I/II module is an intelligent CAN-bus communication interface that compatible with TCP/IP protocol and supports one/two CAN channel. Using this module will enable PC to connect to CAN-bus network via USB bus, forming the CAN-bus network control nodes for the data processing and data collection for the CAN-bus networks such as bus laboratory, industrial control, intelligent residential zone, auto electronics network, and etc.

CANET-I/II module comes with an electrical isolation module, which could be used to avoid the damage caused by the ground loop and enhance the system reliability when working under a tough environment.

CANET-I/II module can use CANET-I/II Tester software provided by us to directly finish CAN Bus message sending, and receiving.

### 1.2 Parameters

Application as Ethernet based interface to the CAN bus

Microcontroller STR912FAW44X6(ARM9 Based)

Ethernet 10M/100M

One or Two channels with Controller NXP SJA1000

Baud rates up to 1MBaud, 82C251 Transceiver

CAN 2.0A (11-bit ID standard frames) and 2.0B (29-bit ID extended frames)

Config software available through the Ethernet interface

Examples of Visual C++, C++Builder are available;

Max data flow 3000PS (extend frame)

Operating temperature: -20 to +70

Physical size: (length) 105mm \* (width) 84mm \* (height) 28mm.

Powered by DC (10 to 30V)

### 1.3 Typical applications

CAN-bus network diagnosis and test

Auto electronic applications

Electric power communication network

Industrial control devices

High-speed and large data communications





### 1.4 Ordering Information

Part Number	Operating temperature	Interface
CANET-I	-20°C ~ +70°C	OPEN5
CANET-II	-20°C ~ +70°C	OPEN5

## 1.5 Product Sales list

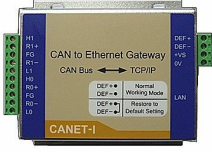
- [1] CANET-I/II Isolated CAN to Ethernet Converter;  
 [2] CD-ROM.(Datasheet, CANET-I/II config and test software, Examples)

## 1.6 PC-CAN Interface Card List

Part Number	Appearance	CAN Channel	Operating temperature	Interface
CANUSB-I (CAN TO USB Adapter)		1	-20°C ~+70°C	OPEN5
CANUSB-II (CAN TO USB Adapter)		2	-20°C ~+70°C	OPEN5
PCI-5001 (Passive PCI CAN Card)		1	-20°C ~+70°C	DB9 male
PCI-5002 (Passive PCI CAN Card)		2	-20°C ~+70°C	DB9 male
CANET-I (CAN TO Ethernet Converter)		1	-20°C ~+70°C	OPEN5
CANET-II (CAN TO Ethernet Converter)		2	-20°C ~+70°C	OPEN5

## Chapter 2 Product Installation

### 2.2 Connector

CANET-II module integrates two CAN-bus channels, while CANET-I integrates one. The pin signal definitions see Figure 2-1, Figure 2-2 and Table 2-1.

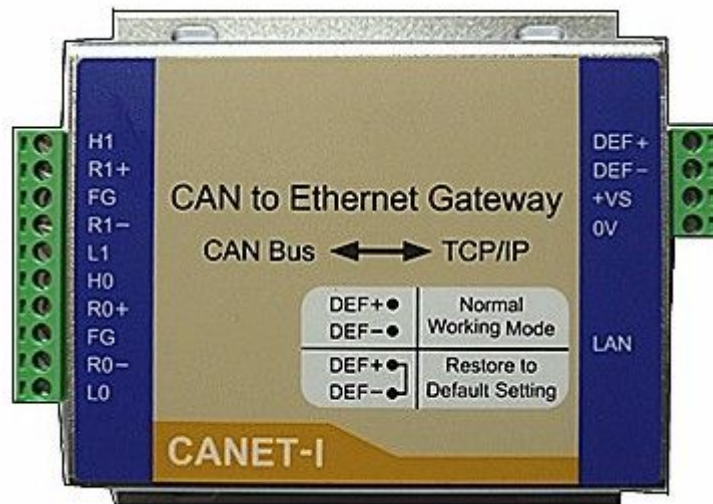

Figure 2-1 : CANET-I CAN interface module

**Table 2-1 : Pin Description**

(Note: CANET-II integrates two CAN-bus channels, CANET-I integrates one CAN-bus channel)

Pin	Channel	Name	Function
1	CAN0	L0	CAN bus Signal L
2		R0-	Terminal resistor R-( internally connected to L0)
3		FG	Shield cable (FG)
4		R0+	Terminal resistor R+( internally connected to H0)
5		H0	CAN bus Signal H
6	CAN1	L1	CAN bus Signal L
7		R1-	Terminal resistor R-( internally connected to L1)
8		FG	Shield cable (FG)
9		R1+	Terminal resistor R+( internally connected to H1)
10		H1	CAN bus Signal H
1	Power	0V	GND
2		+VS	VCC(DC:7-40V)
3	Default	DEF+	<b>When DEF+ and DEF- are short-circuited, the parameters of Ethernet and CAN saved in CANET-I/II module will be changed to default if you restart the CANET-I/II module (see figure 2-4).</b>
4		DEF-	

**2.2 CAN bus connections**

To connect CANET-I/II module to the CAN-bus, user only need to connect CAN\_H and CAN\_L, CAN-bus network adopts straight-line topology, and two terminal 120Ω resistances need to be installed on the two bus terminals. If the number of nodes larger than 2, the 120Ω resistance is not necessary to be installed on the middle node. The length of branch connection should not be longer than 3 meters. The connections for the CAN-bus are shown in Figure 2-3.

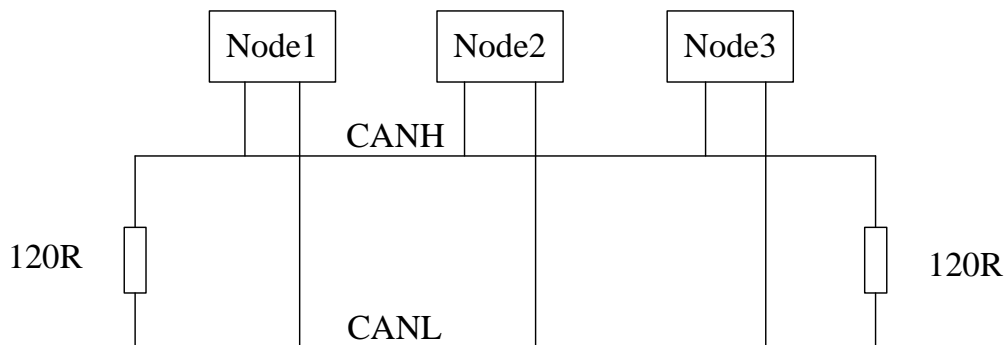

**Figure 2-3: The topology for CAN-bus Network**

## 2.3 Configing and Using the CANET-I/II

### 2.3.1 Introduction for the Config software and parameters.



Figure 2-4: The config software and the default parameter

(1) Main View ->Connect

<b>Device IP Address</b>	IP Address of the CANET-I/II module
--------------------------	-------------------------------------

(2) Main View ->Setup->Ethernet

<b>HostIP</b>	IP Address of the host, such as PC or other device with Ethernet interface
<b>HostUdpPort</b>	Port of UDP protocol of host
<b>DeiveIP</b>	IP Address of the device (CANET-I/II module), which you want to setup
<b>DeiveceUdpPort</b>	Port of UDP protocol of the device (CANET-I/II module) , which you want to setup

(3)Main View ->Setup->CAN0 or CAN1

<b>AccCode</b>	AccCode corresponds to four registers in SJA1000. You can refer the datasheet of NXP SJA1000 controller. $ACR0=(AccCode \gg 24) \& 0xFF$ $ACR1=(AccCode \gg 16) \& 0xFF$ $ACR2=(AccCode \gg 8) \& 0xFF$ $ACR3=(AccCode \gg 0) \& 0xFF$
<b>AccMask</b>	AccCode corresponds to four registers in SJA1000. You can refer the datasheet of NXP SJA1000 controller. $AMR0=(AccMask \gg 24) \& 0xFF$ $AMR1=(AccMask \gg 16) \& 0xFF$ $AMR2=(AccMask \gg 8) \& 0xFF$ $AMR3=(AccMask \gg 0) \& 0xFF$
<b>Filter Mode</b>	Single Filter or Dual Filter.
<b>BTR0 or Timer0</b>	Baud rate timer 0.
<b>BTR1 or Timer1</b>	Baud rate timer 1.
<b>Self TX-RX</b>	Normal or Self TX-RX.

### 2.3.2 Using the CANET-I/II

- (1) **Modify the IP address of the PC so that the CANET-I/II module and PC are on the same network segment.**
- (2) **Power the CANET-I/II module with a DC of 9-40V.**
- (3) **Insert the LAN cable into the plug labeled LAN and connect it either to a hub or switch, or directly to the PC using a crossover cable.**
- (4) **Run CANET-I II Config.exe.**  
(CDROM \ CANET\Config & Tester\CANET-I II Config.exe)
- (5) **Using the CANET-I II Config software to modify the parameter of Ethernet and CAN port.**
- (6) **Run CANET-I II Tester.exe.**  
(CDROM \ CANET\Config & Tester\CANET-I II Tester.exe)
- (7) **Click the “Connect” button.**
- (8) **Now you can send and receive any CAN packet based on CAN2.0A or CAN2.0B.**



## Chapter 3 Application Software development

### 3.1 Communication Protocol

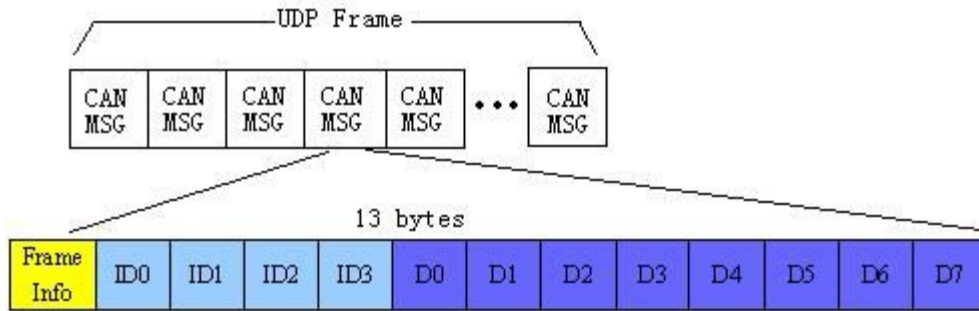

Figure 3-1: CAN packets in UDP Frame

1) Frame Info :

Bit7	Bit6	Bit5	Bit4	Bit3	Bit2	Bit1	Bit0
FF	RTR	Reserve	Reserve	DLC3	DLC2	DLC1	DLC0

**FF** 0:standard frame, 1: extend frame。

**RTR** 0: data frame, 1: remote frame.

**DLC3~DLC0** data length, the max value is 8 according to the CAN2.0A or CAN2.0B.

2) ID

ID0	ID1	ID2	ID3
-----	-----	-----	-----

ID of the frame

A example of ID=0x3FF

00h	00h	03h	FFh
-----	-----	-----	-----

Another example of ID=0x12345678

12h	34h	56h	78h
-----	-----	-----	-----

3) Data

D0	D1	D2	D3	D4	D5	D6	D7
----	----	----	----	----	----	----	----

Data of the frame, the maximum of the data number is 8 according to the CAN2.0A or CAN2.0B.

A example of DLC3-0=8

11h	22h	33h	44h	55h	66h	77h	88h
-----	-----	-----	-----	-----	-----	-----	-----

A example of DLC3-0=6

11h	22h	33h	44h	55h	66h	00h	00h
-----	-----	-----	-----	-----	-----	-----	-----

#### 4) Examples of CAN frame

Extend frame, data frame, ID=0x12345678, DLC3-0=8, data= ( 11h,22h,33h,44h,55h,66h,77h,88h )

88h	12h	34h	56h	78h	11h	22h	33h	44h	55h	66h	77h	88h
-----	-----	-----	-----	-----	-----	-----	-----	-----	-----	-----	-----	-----

Stand frame, data frame, ID=0x3ff, DLC3-0=6, , data= ( 11h,22h,33h,44h,55h,66h )

06h	00h	00h	03h	ffh	11h	22h	33h	44h	55h	66h	00h	00h
-----	-----	-----	-----	-----	-----	-----	-----	-----	-----	-----	-----	-----

#### 5) Note

**When you send the UDP packet from PC to CANET-I/II module, the max number of CAN packets in every UDP packet is 40. In addition, when you finish sending a UDP packet including 40 CAN packet, you should delay about 10ms (CAN baud rate is 1MBps).**

### 3.2 Examples

Examples of Visual C++, C++Builder are available in CDROM.

**Appendix A: SJA1000 standard Baud rate****(Oscillator Frequency=16MHz)**

CAN Baud rate	BTR0 or Timer0(Hex)	BTR1 or Timer1(Hex)
5Kbps	0xBF	0xFF
10Kbps	0x31	0x1C
20Kbps	0x18	0x1C
40Kbps	0x87	0xFF
50Kbps	0x09	0x1C
80Kbps	0x83	0Xff
100Kbps	0x04	0x1C
125Kbps	0x03	0x1C
200Kbps	0x81	0xFA
250Kbps	0x01	0x1C
400Kbps	0x80	0xFA
500Kbps	0x00	0x1C
666Kbps	0x80	0xB6
800Kbps	0x00	0x16
1000Kbps	0x00	0x14